



Compatible inverter brands

**Deye** **GROWATT**

**solis** **SOLINTEG**

**FOX**  
ESS



# 215kWh BATTERY

Air Cooling Commercial & Industrial Battery System Solution

## Flexible

Highly integrated  
All pre-assembled  
Extendable

## Reliable

DC electric circuit safety protection  
Multi level battery protection  
Fire suppression system

## Efficient

Intelligent cooling system  
< 10ms Switching Off /  
On-grid

## Smart

Intelligent cloud platform  
management, real-time  
monitoring of operational status

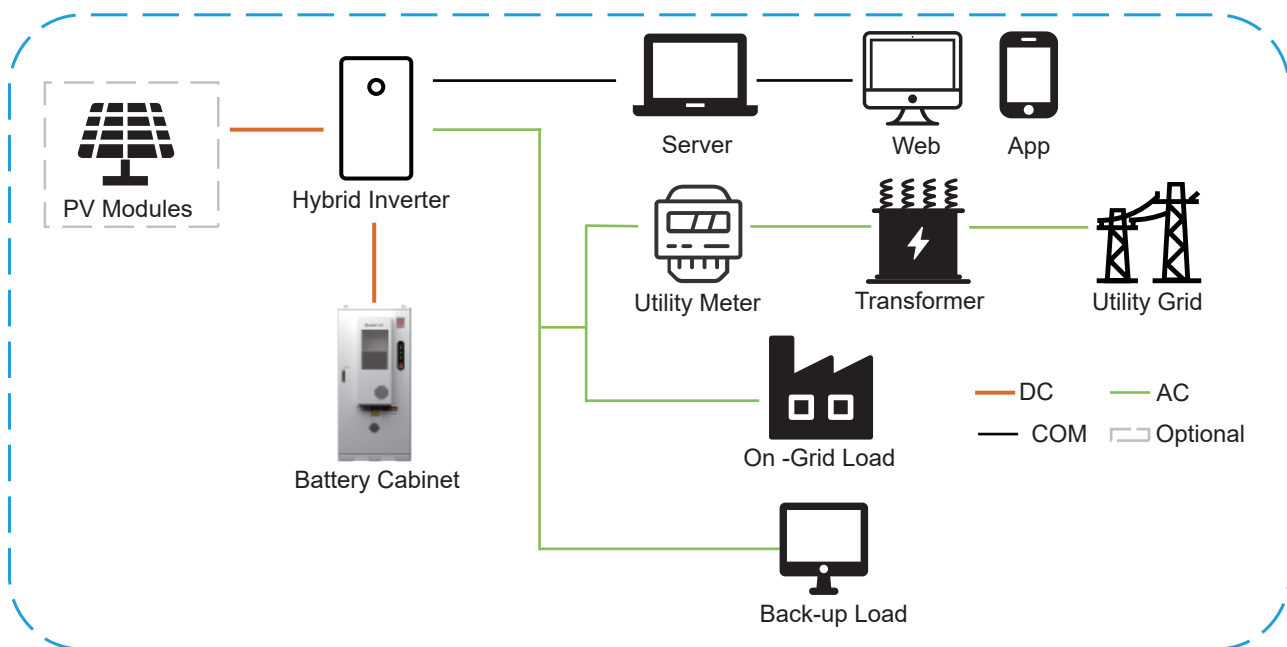

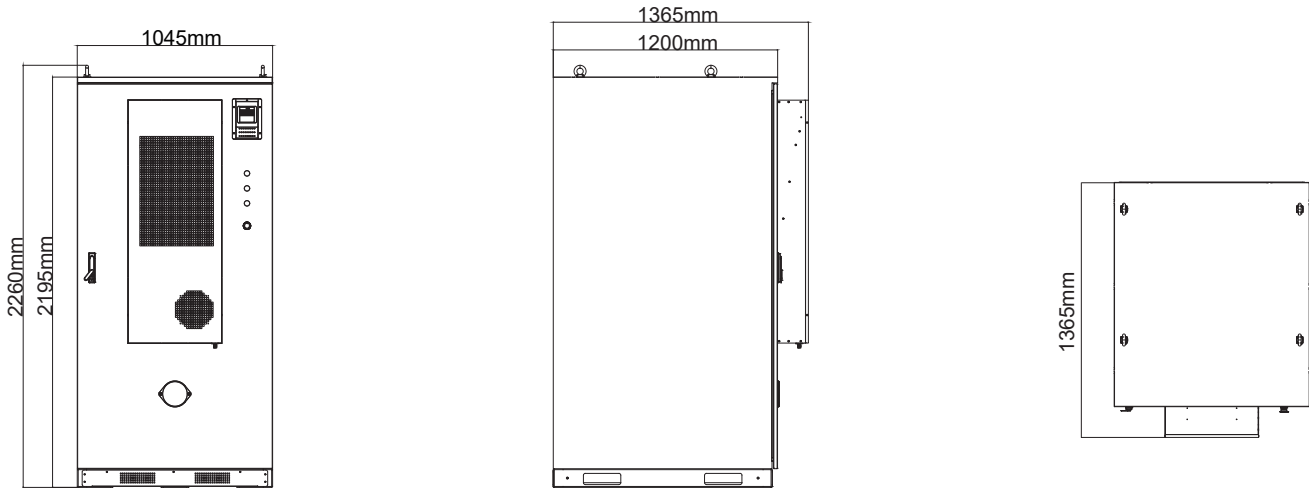

Model	SKTESS215
Battery Type	LiFePO4
Cell Capacity	280Ah
Pack Configuration	1P16S*15
Nominal Capacity	215.04kWh
Nominal Voltage	768V
Operating Voltage Range	672~ 852V
Max.Continuous Charge / Discharge Current	140A
Charge / Discharge Rate	0.5C
Ingress Protection	IP54
Anti-Corrosion Grade	C3 (C4 Optional)
Cycle Life	Cycle Life ≥ 6000 / 5 Years ( @25°C ± 2°C , 0.5C / 0.5C, 70% EOL )
Charge Operating Temperature	0°C ~45°C
Discharge Operating Temperature	-20°C~50°C
Operating Temperature Range	-20°C~50°C
Relative Humidity	5~95 % ( non-condensing )
Communication	CAN/RS485
Cooling	Air Cooling
Dimension	1045 × 1365 × 2195mm
Weight	≤2000kg
Max. Parallel	5

\* Subject to actual delivery